

# Signal Design and Maintenance of Configuration Information

ESI-05-14

## Applicability

ARTC Network Wide

SMS

## Document Audience & Main Points

Audience	Main Points
Signal Designers, Signal Maintenance Engineers, Signal Construction Engineers and Signal Project Engineers	<p>Any renewal of or alteration to signalling equipment requiring new or amended Signal Design, must</p> <ul style="list-style-type: none"> <li>• obtain the appropriate master records from the Drawing Management System (DMS)</li> <li>• undergo correlation of signalling records, equipment and wiring on site to check the accuracy of source records as the basis for any design alteration</li> <li>• undergo a full design check and verification of all signalling design alterations in preparation and prior to commissioning</li> <li>• follow a strict process of updating the master signal design records</li> <li>• identify all clearance points and ensure their physical dimensions on site are accurately correlated and recorded on the signal plans.</li> <li>• for any Signalling System Substitution, control tables must be used to ensure the substitute system design includes all the existing, installed interlocking conditions</li> </ul>

## Document Status

Version #	Date Reviewed	Prepared by	Reviewed by	Endorsed	Approved
1.0	5/07/2017	Standards	Stakeholders	Manager Standards	Acting General Manager Technical Standards 04/07/2017

## Contents

1. Background
2. Source Design Records Assurance and Correlation
3. Signalling System Substitutions Design
4. Commissioning Readiness Review
5. Master Signal Design Records
6. Clearance Points between converging tracks
7. Example Case Studies
8. Appendices

## 1. Background

There have been some cases that have required redesign or the cancelling of a commissioning because the new design was not consistent with the installed signalling equipment. Installing changes to signalling when the base signalling installation is different to the design drawings may lead to a critical safety incident.

This engineering instruction applies to all configuration changes of signalling equipment. It aims to provide guidance and clarity to the important signal design process steps related to Source Design Records, the design being ready for commissioning and the configuration management of master records.

### 1.1. Safety Objective

To ensure that, in situations where renewal or reconfiguration of signalling equipment requires changes to the engineering drawings and/or signalling data, the configuration management of the signal engineering drawings and data is rigorously applied.

## 2. Source Design Records Assurance and Correlation

It is critically important that the signalling design is based on source records, which are a replica of the master as-built records and that these records accurately reflect the existing equipment configuration and installed wiring on site.

A prime cause of many safety incidents on the signalling infrastructure occurs when there is poor correlation between as-built records and the in-service existing signalling apparatus, circuits and data on site.

Poor correlation is due to:

- inadequate record control when the original works were installed.
- site equipment or wiring that has been altered without the corresponding master records being updated.
- multiple schemes at the same location that have been installed in a different order to that for which they were designed.
- works installed but never commissioned

***Prior to any alterations being made to the design of a signalling system, a check shall be made to confirm that the as-built records correlate accurately with what is installed at site.***

Signal design records encompass a wide range of documents, such as signal plans, bonding plans, cable plans, circuit books and drawings, control tables, interlocking data, Phoenix data, telemetry data, LX monitor data, etc.

The assurance and correlation process steps are as follows. These are to be documented and detailed on form ESI0514F-01:

### 1. Obtain Master As-built Records (drawings and data)

- Nominate all the as-built records required for the signalling design work
- Book out a new Engineering Job Number and all the nominated as-built records from ARTC's DMS or other approved DMS

### 2. Desk Top Correlation

- A correlation copy set of documents must be produced from the nominated as-built records
- Check that all recent jobs have been completed and are reflected on the as-built records Amendment Sheet (AS1) and

- check if there are any outstanding Certified Commissioning Copies (CCCs) not incorporated in the as-built drawings
- Check if other works are proposed or currently being designed or installed
- Check with signalling maintenance representative for the nominated location if additional works have been completed or are to be undertaken
- Check with signalling maintenance representative if there are any known discrepancies between the as-built drawings and the installed equipment
- Resolve any discrepancies, update outstanding Certified Commissioning Copies (CCCs) and mark up the correlation copy accordingly
- The signal design engineer / designer shall determine the level of site correlation required to confirm the accuracy the correlation copy to what is existing on site.
- The above are recorded on Form ESI0514F-01 sections 2 to 8.

### 3. Site Correlation

- Apply the following steps for site correlation using the correlation copy from step 2 above:
  - Equipment check, which is to include:
    - Equipment items and
    - Rack layout checks
  - Wire and Null Count
  - Wire Hand Trace (provided risks of interference are low)
  - Book out and Bell Test (high risk locations eg wiring degradation)
  - Check Clearance Points by measurement
  - Configuration of trackside equipment (eg point machines RHSNC or LHSNC, track circuits polarities, etc.) Refer Appendix B
- *Site correlation shall be carried out by persons who have recognised competency in accordance with ARTC's competency management system.*
- Any deficiencies found shall be investigated and corrected
- Resolve any discrepancies and mark up the correlation copy accordingly; the mark ups shall be independently verified (refer to Appendix A for examples)

### 4. Source Design Records Correlation Confirmation

Form ESI0514F-01 is to be completed and signed off by a person with the appropriate competency.

### 5. Signal Design Commencement

The signal designer may only commence design work after receiving the signed form ESI0514F-01 alongwith the marked up correlation copy and the corresponding set of source design records (drawings and data)

## 3. Signalling System Substitutions Design

Signalling System Substitutions (sometimes referred to as “interlocking heart transplants”) require the existing interlocking conditions to be exactly replicated in the substitute system. This is fairly straightforward if the existing interlocking has up to date control tables.

However, if control tables are not available, a set of control tables must be created to accurately reflect the existing interlocking conditions. This usually means reverse engineering the control tables from existing relay circuits. The following must be addressed:

- Any special/novel locking requirements, which are not covered in ARTC's Common Signal Design Principles ESD-05-01, must be clearly included in the “Remarks” section of the appropriate control table.
- The SFS (Signalling Functional Specification) must also be updated to include any special/novel requirements (under Special Design Requirements).

- There shall be an Operations Requirements Specification detailing all train operations in the area affected by the signalling works. The Principles Tester and Design Verifiers shall ensure that the new design is suitable for the intended train operations.
- Control tables must be designed/checked/verified by persons with the appropriate minimum level 2 competency. This also includes associated data, circuits and bonding plans. Persons under mentorship are specifically excluded from this task for Signalling System Substitution Designs.
- Any existing design features not consistent with the current standards must be reviewed and covered by an Engineering Waiver.
- NOTE: the requirements of ESI-05-13 - Signal Design and Standards Applicability apply to these works and the default is for the design to be upgraded to current standards.
- For the Checking/Verification/Validation process
  - Care must be taken with review/verification logs that the meaning is clear and not easily misinterpreted by the designer amending the design
  - As part of the independent verification process, a final cross check must be performed to ensure any pre-existing novel requirements in the existing relay interlocking circuits/SAP have been replicated in the data, before the data is released for design integrity testing.
  - Design integrity test logs that require no further action must go through the same process as if these logs required modification. That is, they must be reviewed and signed off by the designer, checker and independent verifier.
  - Before the Commissioning Readiness Review, a minuted close out meeting must be held between the Principles Tester, Independent Verifier, Design Checker and Designer to ascertain all special/novel locking requirements have been addressed,

The above process also applies to any upgrades to level crossings.

#### 4. Commissioning Readiness Review

A Commissioning Readiness review of the new signalling works is required to be undertaken before the commissioning can proceed. This is detailed in the standards covering Commissioning and Commissioning Work Packages.

A principal purpose of the review is to ensure that any construction feedback and/or amendments to the design found during site installation have been fully incorporated in the design and have undergone the full verification process.

Any signal design modifications must be in accordance with current engineering standards. Where the situation is such that updating to current standards is unwarranted, it must be covered by an engineering waiver.

This review also provides a final check that all the design documents and data have undergone the full design processes and that all configuration management documentation is in place and signed off ready for commissioning. Where the design was for a Signalling System Substitution, the final check must include the minutes of the close out meeting.

Form ESI0514F-02 is to be completed and signed off by the signal design manager. Until this review is signed off as complete, the commissioning must not proceed.

## 5. Master Signal Design Records

After completion of the commissioning and the new as-built records are complete and verified to the CCCs, the new as-built records must be booked in to the DMS as the new master as-built records. The allocated Engineering Job Number must be closed.

Form ESI0702F-05 is to be completed and signed off by the signal design manager for the project / works.

Form ESI2505F-01 is to be completed for the signalling works. This shows the complete configuration of the signalling and related systems. This shall be submitted with form ESI0702F-05 for recording in the Drawing Management System.

## 6. Clearance Points between converging tracks

The signalling system uses track sections from track circuits or axle counter sections to check that a train path is clear for the passage of a train. Where tracks converge or diverge then there needs to be a defined clearance point that all other trains or rollingstock is clear off for the signal to show a proceed aspect.

For a turnout with no cant on either diverging track then the clearance point is where the running face of the two adjacent rails is separated by a distance of 2170 mm. This ensures a minimum clearance (safety margin) of 200 mm between the rollingstock clearance outlines applicable.

If there is cant on the track then the clearance point needs to be calculated by the track design engineer using the kinematic envelope.

The signalling insulated rail joint for track circuits or the position of an axle counter head shall be 3.5 metres minimum from the clearance point. This allows for a 3.5 metre overhang of the headstock of a wagon or rollingstock past the last axle.

The signal design engineer / designer shall indicate on the **signal bonding plan** every location of a clearance point that is used within the signalling design. The signal arrangement plan because of it is non-scale in the lateral direction may be deceptive as to clearance between tracks.

The signal design engineer / designer shall include a table in the Control Tables detailing every clearance point and the signal routes or locking that is dependent on the clearance point.

The Commissioning Work Package shall include a specific Work Instruction to check and measure and record the clearance available at each clearance point listed in the control tables.

In the example at Figure 1 below, clearance is required between the block joint at signal 33 and the adjacent road.

In the example at Figure 2 below, there is no clearance point between 157A turnout and 159A turnout. Thus 13BT track section must be unoccupied for a signalled route through 157A reverse. This requirement would apply for a shunt route.

In example at Figure 3 below the insulated rail joint between 7AT and 23AT is not clear of 24AT track for a train traversing 107 points reverse. Routes across 107 points reverse would require 7AT track section to be unoccupied.

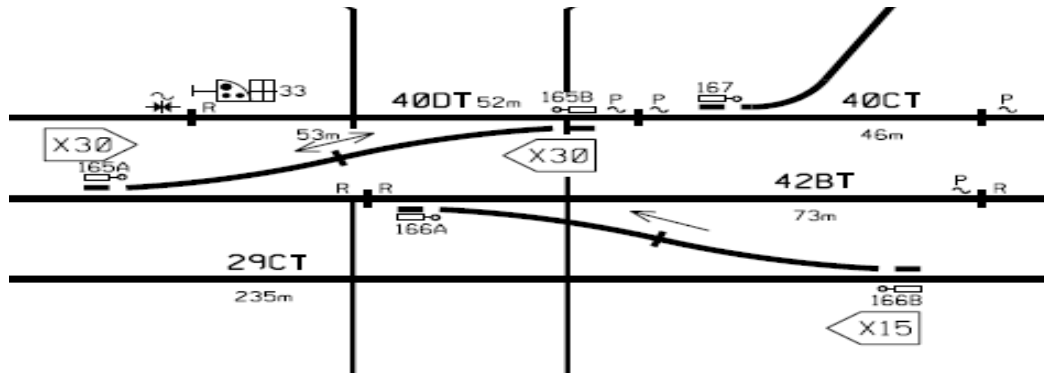

Figure 1 Clearance Point for 33 signal

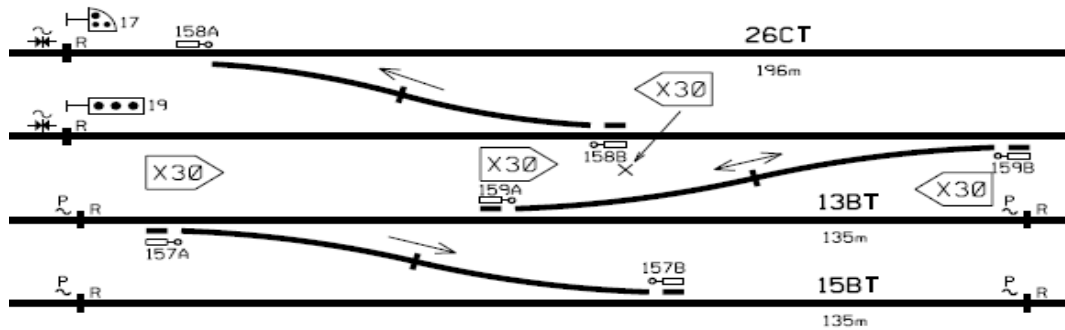

Figure 2 No Clearance Point between 157A points and 159A points

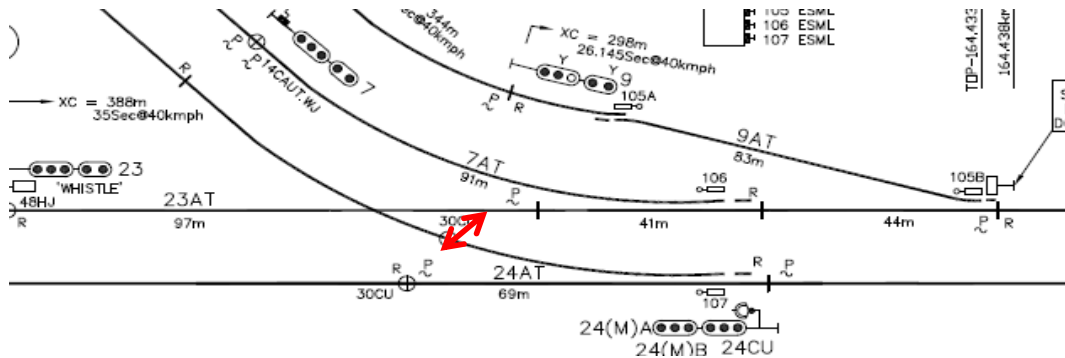

Figure 3 The Signal Arrangement Plan is deceptive as there is not sufficient clearance at this insulated rail joint between 7AT track section and 24AT track section

## 7. Example Case Studies

### Case Study 1

Delayed commissioning of a turnout renewal due to design issues being identified during the commissioning. Reasons were attributed to:

- no correlation carried out of the as-built installation prior to commencement of the design
- Commissioning Readiness Review accepted the design, which was 6 months old and had not been updated to site correlation and pre-commissioning activities
- No signalling design manager allocated from design initiation to commissioning

### Case Study 2

An operational incident with 2 trains having a near-miss collision at a junction where the track circuit joint was not positioned beyond the clearance point and the interlocking did not prevent a conflicting move. Reasons were attributed to:

- no correlation carried out of the as-built installation prior to commencement of the design
- no measurement of clearance points during testing and commissioning phases

### **Case Study 3**

A relay interlocking was replaced by a Microlok system. An incident occurred where a stored shunt route was set with another train in the section. Although this is not considered contrary to signalling principles, the Microlok did not prevent the route as did the original relay interlocking. Reasons were attributed to:

- there was no flank protection or deadlocking of the points for the first train movement
- special design requirements were not carried forward to the new design

## Appendix A - Examples re Correlation

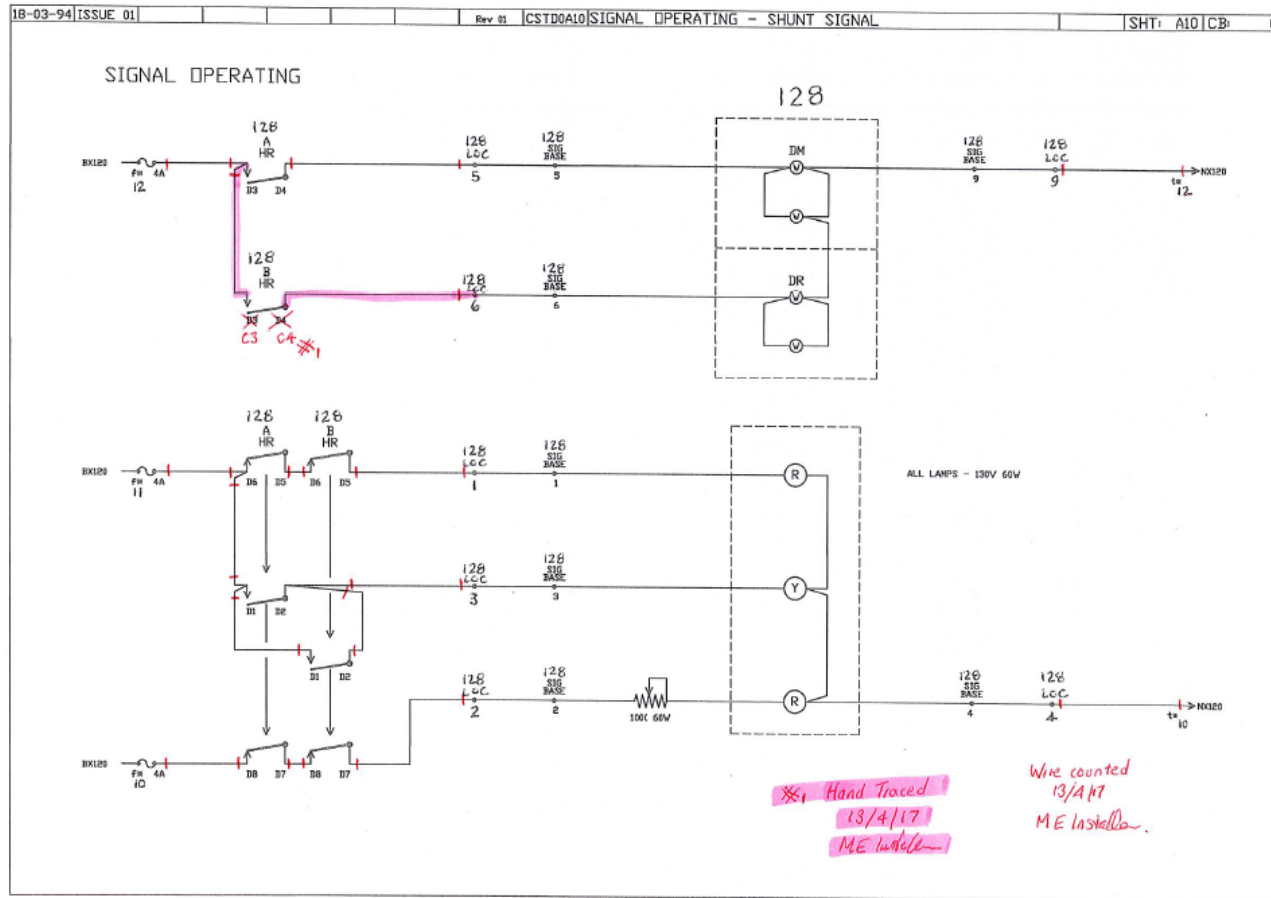

Example 1



## Appendix B – Correlating Point Motors and Detectors

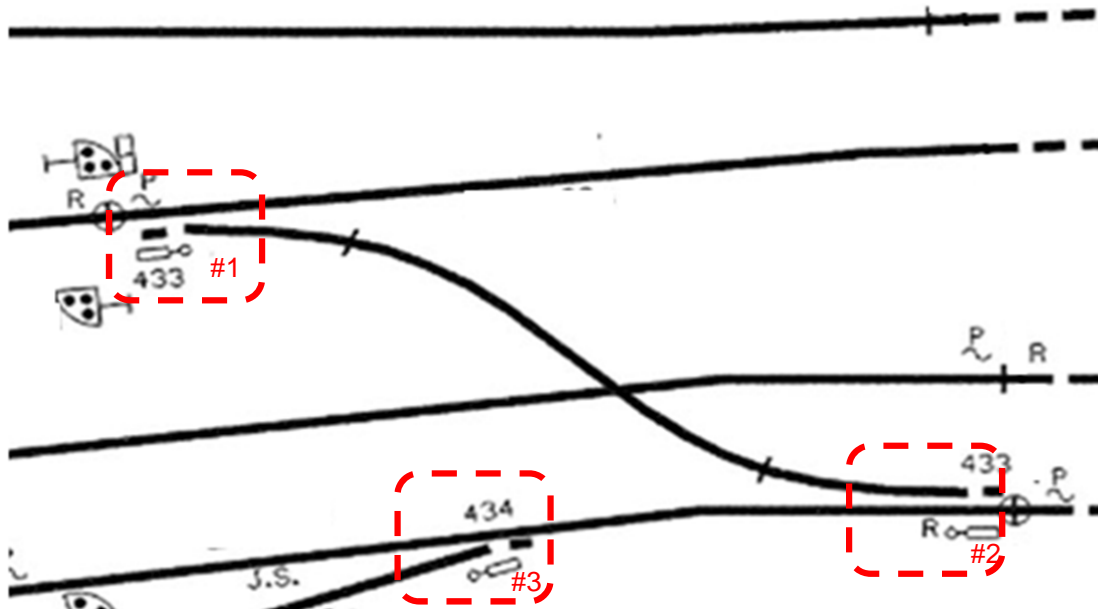

When correlating points, it is important to check what hand the points are and that the drive and detection circuits are wired to the appropriate standard drawings for the particular points machine being used.

For example in the layout shown above:

- #1. Points are RHSNC (Right Switch Normally Closed) with points machine mounted on the right
- #2. Points are RHSNC with points machine mounted on the left
- #3. Points are LHSNC (Left Switch Normally Closed) with points machine mounted on the left

If the points were Westinghouse 84M machines, the standard circuits for #1 and #2 would be SDS25 sheet W18 part 2/2 for detection and sheet W17 part 1/2 for points motor wiring.

The standard circuits for #3 would be SDS25 sheet W18 part 1/2 for detection and sheet W17 part 2/2 for points motor wiring.

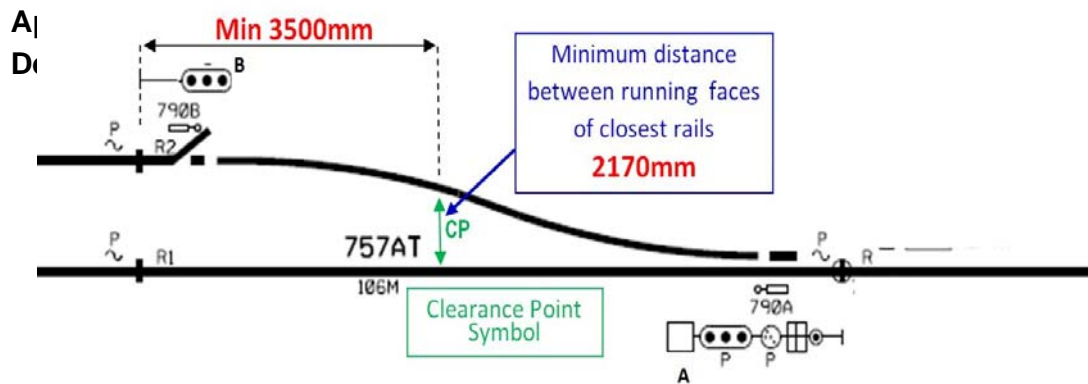

For each turnout, the CP is to be shown on new and newly amended ARTC Signal Bonding Plan. This is to show where the train detection limit has to be located beyond the CP such that a train on one route will not collide with a train on the other route at the fouling point. The diagram above shows the minimum distances for the clearing point and the associated track circuit joint or axle counter head. This ensures a "passing clearance" for a minimum space between vehicles and an allowance for vehicle overhangs.

It is not always possible to place train detection limits on the "correct" side of the CP. If this is the case, the interlocking design must treat it as being foul to prevent conflicting moves.

Note the CP distance from the point ends will depend on the speed of the turnout. Higher speed turnouts diverge much more gradually and this will lead to the CP distance to the point ends being greater than for lower speed turnouts.

Using the example layout above, if a train signalled past signal A via 790 points normal stops just beyond track circuit 757A joint R1, it will allow 790 points to be free to move reverse for routing a train from signal B. If the track circuit joint R1, was located inside the CP nearer the points, then a train signalled from signal B through 790 points reverse could potentially strike the stopped train.