

A telephone circuit, in addition to transmitting telephone messages, must handle certain telephone signaling functions necessary for the operation of the telephone system. Even the most primitive telephone circuit requires some form of signaling to announce that one terminal desires to talk to the other. In more complex systems, a variety of signaling functions may be required. In general, these may be classified as signals used for establishing a connection, and signals that pass information concerning the status of the circuit or call.

Traditionally, different techniques have been used for signaling over a telephone subscriber's local circuit or loop than have been used between offices, and over long distance toll circuits. Different techniques were used because of the different signaling requirements existing for each type of path.

Signaling falls into three basic categories: supervisory signals, information signals, and control signals. Supervisory signals tell the telephone office that a connection is desired, or that it is no longer being used. Information signals tell the subscriber or the operator the status of the call, or the condition of the circuit. Control signals provide directions for establishing the desired connection.

One of the earliest methods of signaling employed a magneto or AC generator located at the subscriber's telephone. The desired supervisory signal was transmitted by cranking the magneto. The resulting 15- to 20-cycle AC voltage attracted the operator's attention by actuating a "drop" on the switchboard. The "drop" was an indicating device consisting of a panel light with a hinged metal plate in front of it. The metal plate was hinged at the bottom and latched at the top in such a fashion that a ringing signal would release the latch and allow the plate to swing down, uncovering the light. When the call was completed, another crank of the magneto notified the operator that she could break the connection. Magneto supervision is still employed in some locations, particularly where the subscriber is remote from the central office. In such a case, each telephone instrument may have its own battery for supplying voice current power.

A much more commonly used type of supervision is known as common battery supervision, which has nothing to do with the quality of the batteries used. When the customer lifts his instrument from its hook, a DC path is completed through a loop consisting of the customer's instrument, a

TELEPHONE SIGNALING PRINCIPLES

By A. R. Meier
Lenkurt Electric Co., Inc.

Formerly associated with the applications engineering department, Mr. Meier is editor of the *Lankurt Demodulator*, a technical publication.

battery in the telephone office, and a line relay. When the customer closes the loop, the relay is energized, thus connecting the customer's line (or loop) to the operator's board, or to automatic dial equipment. When the calling subscriber releases his instrument on its hook, the circuit is broken, and the relay releases the circuit. This method of supervision gets its name from the battery which is common to both the office and the subscriber. Table 1 summarizes various loop signaling methods.

In order to know whether the called party's instrument is on-hook or off-hook, some means of supervision is required by the central office. The most widely used method is known as reverse battery supervision. When the called party lifts his instrument from the hook, a relay in the office trunking equipment responds to the closed loop, actuating a supervisory relay that reverses trunk polarity. This battery reversal is detected by a polarity-sensitive relay at the calling end of the circuit. The caller's trunking equipment may reverse the polarity of the caller's loop. Fig. 1 illustrates a typical reverse-battery method of supervision.

Interoffice signaling usually involves different considerations than in the subscriber loop signaling described above. In many cases, the use of carrier or radio to provide the interoffice circuit precludes loop signaling methods. In such cases, some form of E & M signaling may be used.

E & M signaling is characterized by the use of separate paths for the signaling and the voice signals. E & M signaling acquired its name from arbitrary letter designations appearing on early circuit drawings for systems using this type of signaling. The M

lead transmits ground or battery to the distant end of the circuit, while incoming signals are received as either a grounded or open condition on the E lead. Thus, the M lead reflects the conditions existing at the far-end of the circuit. Various simplex, duplex, composite, and other circuit arrangements have been devised to permit E & M signaling between offices on a DC basis.

Although many signaling functions depend on DC or metallic signaling paths, obviously these paths cannot be carried over radio or carrier links. Carrier systems must, therefore, translate these DC signals into a form that can be transmitted, then restore them to their original form for use by the office trunking equipment.

Fig. 2 illustrates one approach to transmitting loop-dial, reverse-battery signaling over a carrier system. In the typical carrier system, a single signaling tone is used. Carrier signaling tones always lie within the pass-band of the carrier channel equipment, but may be either within the channel voice band or just outside it.

In the system shown, a signaling tone is transmitted over the carrier system in both directions. When a party at one end of the system picks up his telephone to make a call, his DC loop is closed. This applies battery to relay A, causing it to close. One set of contacts removes the signaling tone from the outgoing path, thus preparing the circuit for dialing and for the voice-frequency message that will follow the dialing. Another set of contacts on relay A energizes relay B, thus grounding the sleeve lead of the local telephone circuit. At the far end, incoming signaling tone is constantly monitored and used to keep the far-end D relay energized. When the signaling tone is interrupted by the sending telephone being removed from its hook, far-end relay D is de-energized. This connects a terminating resistor and a series diode across the tip and ring of the far-end loop. In addition, relay C and a series diode are also connected across the tip and ring of the far-end loop. The two diodes are connected so that current may flow through either the terminating resistor or the C relay, but not both. Loop polarity determines which will conduct. At first, current flows through the terminating resistor used to provide a partial termination to the carrier terminal hybrid circuit.

When the calling subscriber pulses his transmit A relay by dialing, the signaling tone transmitted over the carrier system is also pulsed. This causes the receive D relay to repeat these pulses through the terminating resistor and local trunking equipment.

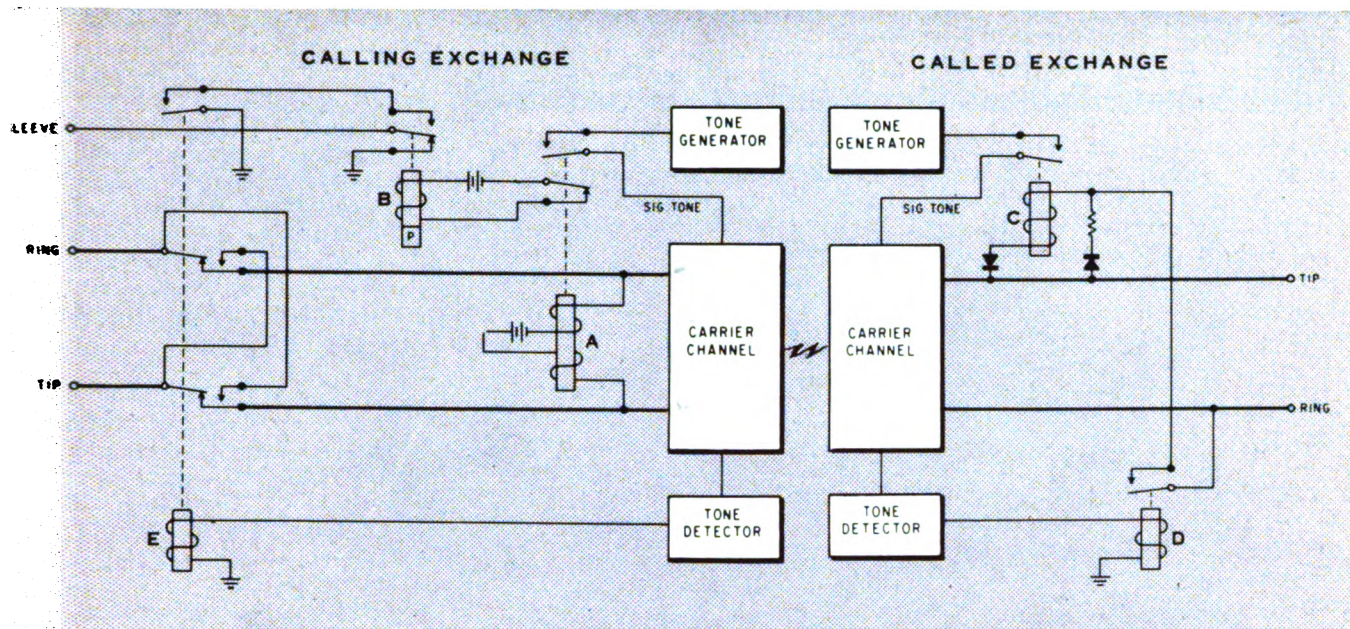

Figure 2—Arrangement for transmitting loop-dial, reverse battery signaling over a carrier system, between exchanges.

In this system, a single signaling tone is used, which lies within the carrier channel pass-band.

When the called party answers, far-end trunking equipment in the office reverses battery polarity across the line. This reverse polarity cuts off the induction through the terminating resistor because of the polarity of its series diode, and permits current to flow through the C relay. The C relay energizes, thus stopping the transmission of signaling tone back to the calling end. At the calling end, interruption of signaling tone permits the A relay to de-energize. This reverses polarity of the transmit line and provides the required line supervision to the transmitting office equipment.

In a system like the one just described, signaling units associated with the carrier equipment substitute for the metallic paths over which DC signaling is normally carried. In other carrier systems, similar approaches are often used. Although the signaling principles may be similar, the specific circuit arrangement used by one organization may differ from that used by another in some detail such as polarity. Carrier equipment linking two systems employing different signaling methods must be designed to accommodate and translate one signaling method to the other. This requires careful planning and design of carrier signaling equipment. The carrier equipment designer's problem is magnified by the need for adapting standard carrier equipment to private communications systems which may use signaling methods not normally encountered in public telephone service. For this reason, carrier equipment designed for subscriber service often includes provisions for ready substitution of signaling components.

RSC

TYPE OF SUPERVISION	CALLING END		CALLED END		BATTERY SOURCE
	SEIZURE (CONNECT) SIGNAL	DISCONNECT SIGNAL	ON HOOK	OFF HOOK	
HIGH LOW	CLOSED LOOP	OPEN LOOP	HIGH RESISTANCE	LOW RESISTANCE	CALLING END
LOW HIGH	CLOSED LOOP	OPEN LOOP	LOW RESISTANCE	HIGH RESISTANCE	CALLING END
REVERSE BATTERY	CLOSED LOOP	OPEN LOOP	NORMAL LINE POLARITY	REVERSE LINE POLARITY	CALLED END
REVERSE HIGH LOW	CLOSED LOOP FOLLOWED BY BATTERY REVERSAL	BATTERY RETURNS TO NORMAL POLARITY, FOLLOWED BY OPEN LOOP	HIGH RESISTANCE	LOW RESISTANCE	CALLING END
WET DRY	CLOSED LOOP	OPEN LOOP	BATTERY AND GROUND CONNECTED TO LINE	BATTERY AND GROUND REMOVED	CALLED END

Table 1—Typical loop signaling systems.

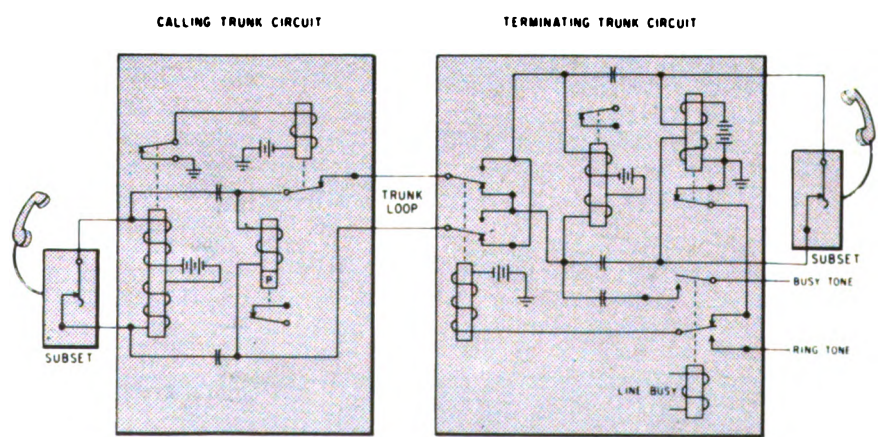

Figure 1—Reverse battery loop supervision circuit. Only supervisory relays shown.